



BOOST-RITE® BOOSTER PUMP

ADVANCED IMPELLER TECHNOLOGY CUTS PRESSURE-SIDE CLEANING COSTS BY OVER 25%*

Pressure-side pool cleaning just got a whole lot less expensive thanks to the eco-friendly Boost-Rite pump from Pentair. This innovative design saves pool owners more than 25%* in energy costs over other booster pumps on the market. With an advanced 5-stage impeller design, the Boost-Rite pump delivers greater water pressure for more powerful and efficient cleaning...at significantly less cost.

Power up your pressure-side cleaner now with a Boost-Rite pump. You'll save money with every cleaning—and enjoy all the performance your pool cleaner was designed to give you.

ENERGY USAGE COMPARISON

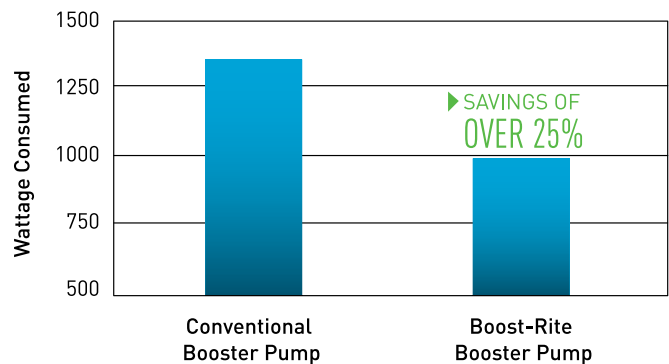

AN ECO SELECT® BRAND PRODUCT

The Boost-Rite Booster Pump has earned the Eco Select brand distinction as one of the greenest and most efficient choices from Pentair.

*Actual energy usage may vary based upon plumbing size and length and other hydraulic factors.

BOOST-RITE®

BOOSTER PUMP

Powerful 5-stage impeller design cuts operating costs by over 25%*

1" fittings are 75% larger in area, for better flow and greater efficiency

Totally Enclosed Fan Cooled (TEFC) motor design allows the pump to run cooler and quieter

Condensed size is 1/3 smaller than competing pumps, taking up less space on the equipment pad

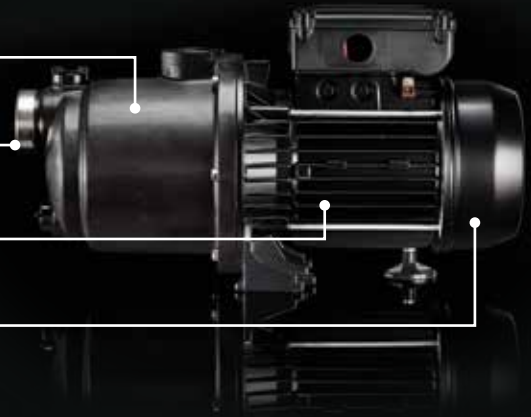

ENGINEERED FOR SUPERIOR ALL-AROUND PERFORMANCE

The Boost-Rite pump delivers more of what you want—lower energy consumption, top performance, easier installation, quieter operation, and greater durability.

- **Lower energy consumption:** Advanced 5-stage impeller design cuts electricity use by over 25%*, offering you substantial savings.
- **Easier installation:** 1/3 smaller than other pumps so it's easier to handle and plumb, yet thoughtfully includes a larger wiring compartment for easier access.
- **Quieter operation:** For a more relaxing poolside experience.
- **Greater durability:** Totally Enclosed Fan Cooled (TEFC) motor runs cooler for longer pump life.
- **More power:** The Boost-Rite pump delivers greater water pressure for more powerful cleaning...at less cost.
- UL and cUL Listed for safety.

AVAILABLE FROM:

PERFORMANCE CURVE

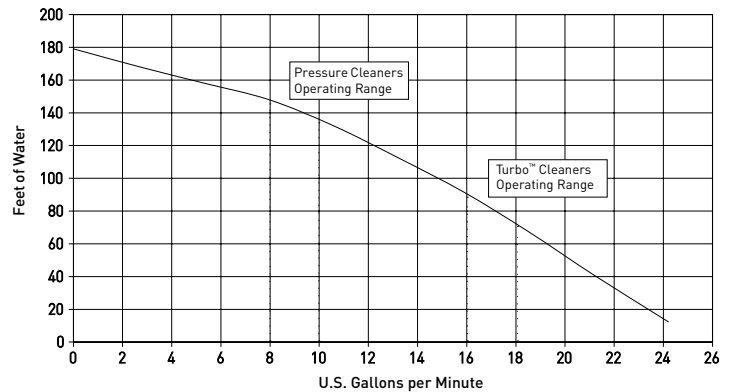

1620 HAWKINS AVE, SANFORD, NC 27330 800.831.7133 WWW.PENTAIRPOOL.COM

All Pentair trademarks and logos are owned by Pentair or one of its global affiliates. Boost-Rite® and Eco Select® are registered trademarks of Pentair Water Pool and Spa, Inc. and/or its affiliated companies in the United States and/or other countries. Because we are continuously improving our products and services, Pentair reserves the right to change specifications without prior notice. Pentair is an equal opportunity employer.

pumps • filters • heaters • heat pumps • automation • lighting • cleaners • sanitizers • water features • maintenance products

8/17 Part # P1-128 ©2017 Pentair Water Pool and Spa, Inc. All rights reserved.

